

# PALPADOR UNIVERSAL



6562-3



6562-4

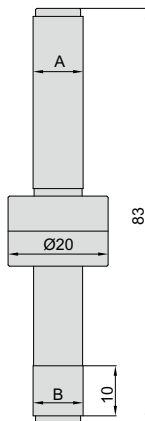

6562-3

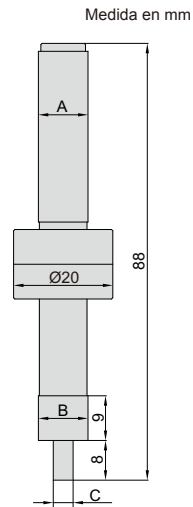

6562-4

Medida en mm

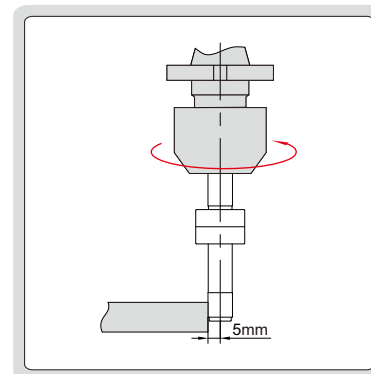

6562-3

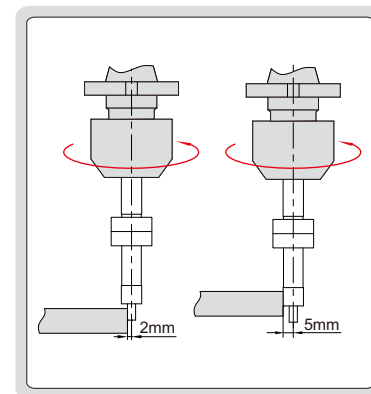

6562-4

- Mango y punto de contacto endurecidos

Código	Mango(A)	Punto de contacto (B)	Punto de contacto(C)	Precisión
6562-3	Ø10mm	Ø10mm	—	5µm
6562-4	Ø10mm	Ø10mm	Ø4mm	5µm