

MEDIDOR DE ESPESORES

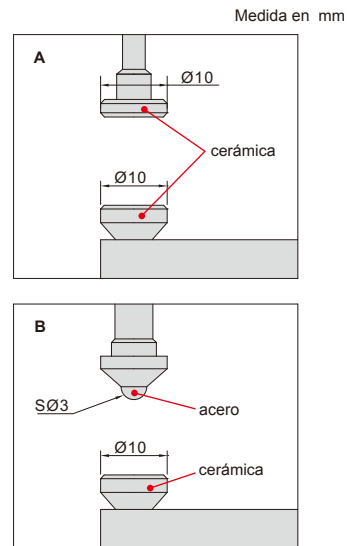

2366-30

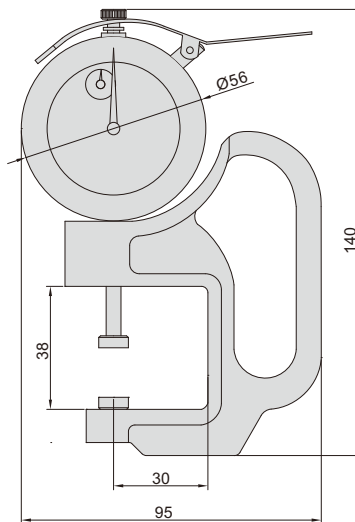

Código	Rango	Graduación	Precisión	Tipo
2366-30	0-30mm	0.01mm	±0.035mm	A
2366-30B	0-30mm	0.01mm	±0.035mm	B